

Information Bulletin 301

Subj: Multilayer (Four Shell) Magnetic Shield Assembly

Introduction

Extremely low magnetic noise environments are required for testing sensitive instruments such as SQUIDS (Superconducting QUantum Interference Devices) and for their practical use in such applications as Non-Destructive Examination (NDE). This requirement can be met with high performance multilayer magnetic shields. One possible configuration is multilayer nested cylinders made of high permeability materials.

In this Product Bulletin, we discuss the design and initial test results on a four layer nested cylinder configuration. Each cylinder was fabricated from AMUMETAL (a trademark of Amuneal Manufacturing Corp.), an 80% Nickel-Iron high permeability shielding material which conforms to ASTM A753-85 and MIL-N-14411C Composition I for operation at room temperature.

The four-shell assembly described here has been designed to accept an additional cylinder of CRYOPERM-10 (a trademark of Vacuumschmelze GmbH), fabricated by Amuneal for operation at cryogenic temperatures within the cryostat which is to be located within the innermost AMUMETAL shell.

The design and fabrication of this multilayer nested cylinder shield configuration was made by Amuneal in collaboration with the Institute of Thin Film and Ion Technology (ISI) at the Forschungszentrum Jülich GmbH in Jülich, Germany (KFA). After delivery of the completed assembly, testing of the four-layer shell configuration was performed jointly by KFA/ISI and Amuneal technical staff.

Further testing of the complete shielding assembly (five shells) is planned for the near future, and the test results will be made available.

Design

Determination of the shield configuration (number of layers, material thickness, and spacing between layers) was made in accordance with the theory of D. Dubbers (Nuclear Instruments and Methods in Physics Research A243 1986, 511-517), and the dimensional requirements of KFA.

As illustrated in Figure 1 below, the shield assembly featured a vertical demagnetization coil designed to maintain a consistent low magnetic noise environment for static field measurements. Spacing components were fabricated from BAKELITE, a non-magnetic, non-metallic insulating material, which can be machined to precise dimensions.

The overall dimensions of the four-layer nested cylinder assembly are 23.6" (600mm) \pm OD x 58.11" (1476mm) high. The assembly consists of four cylinders fabricated from .062" (1.57mm) thick Amumetal, with spacing between cylinders maintained by a minimum of 1.40" (36mm) wide BAKELITE (a Grade C Phenolic) spacer rings. The dimensions of the inner cylinder are 12.598" (320mm) \pm ID x 47.244" (1200mm) high. The four-layer lid assembly included two horizontal handles for ease of removal and replacement, as well as an access hole for the vertical degaussing coil.

The shield design included an internal positioning ring to center the cryostat within the innermost AMUMETAL cylinder, maintaining concentricity and ensuring a homogeneous field distribution over the shielded region. Bottom spacing components provided structural support to avoid possible reduction of permeability due to flexing of the shield material under the weight of the cryostat.

Figure 1

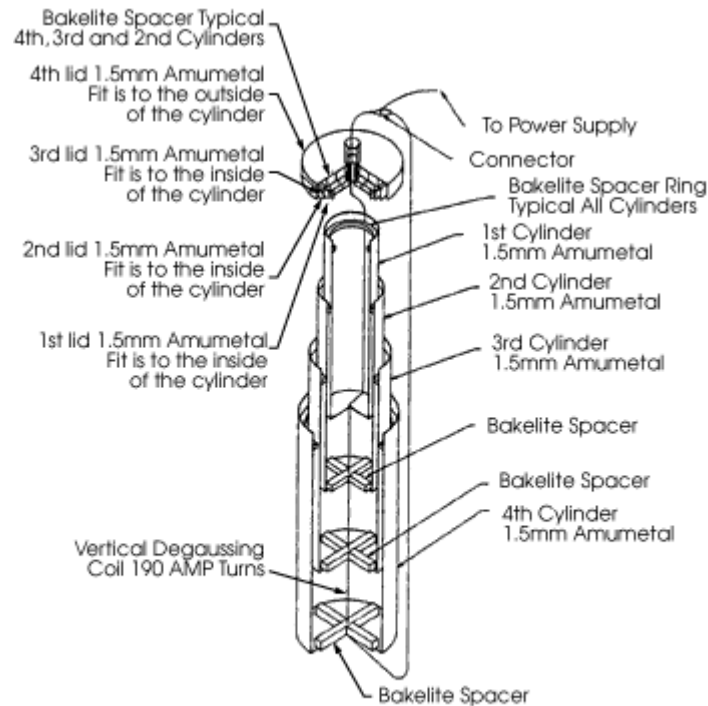

**Nested Cylinder Assembly
(4) Amumetal Layers**



Group of Two Complete Three-Shell Nested Shield Assemblies
plus the Four-Shell Nested Cylinder Assembly With Lid Removed

Set-Up for Testing Shielding Performance

The test set-up was made following guidelines in ASTM 698-74, Standard Method of Test for Magnetic Shield Efficiency in Attenuating Alternating Magnetic Fields.

Figure 2

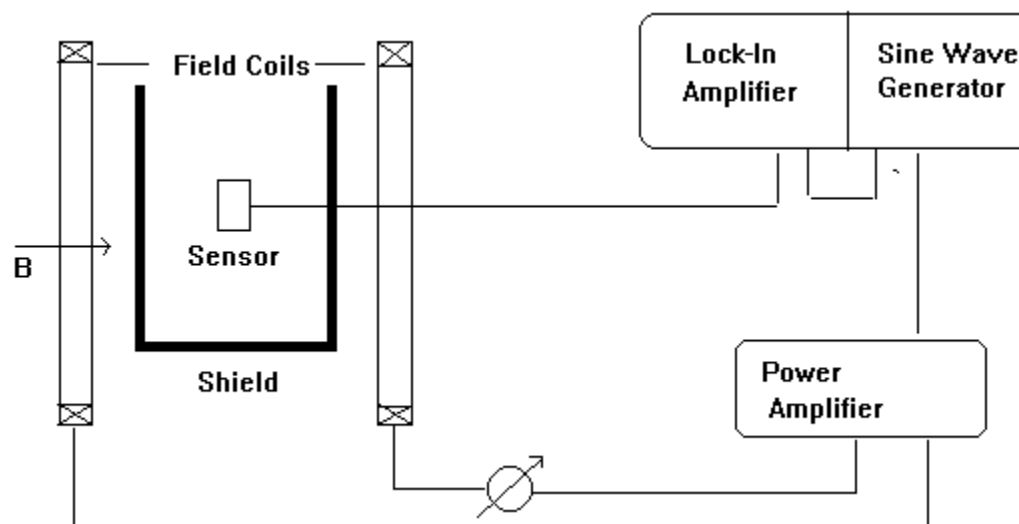

Test Set-Up Block Diagram

Test Results

Three testing configurations were employed to determine the effectiveness of this four-layer shielding assembly at different magnetic field orientation and end-closure conditions.

Test #1: Transverse Field, Complete Assembly

This test was performed with the SQUID Sensor located in the center of the innermost cylinder, the endcap assembly in place, and a transverse field (perpendicular to the axis of the Shield) of $60\mu\text{T rms}$ applied. This condition most closely approximated the shield's intended use in its final application.

An initial test was performed at 10Hz in an effort to take advantage of the low noise level of the SQUID at this frequency. The results were found to be in excess of 59,979,107:1 (155.56dB). Because the signal from the coil was "in the noise" of the measuring instrument, it was determined that the SQUID instrumentation was not sensitive enough to measure the high level of performance provided by the shield at other frequencies. No further tests were performed in this condition.

Test #2: Transverse Field, One End Open

With the SQUID sensor centrally located within the innermost cylinder, a transverse field of $29.154\mu\text{T/A}$ was applied without the endcap assembly in place. This test was designed to assess the type of performance to be expected in applications where complete end enclosure is not possible.

Test #3: Axial Field, One End Open

This test condition was identical to Test #2, except that an axial field (parallel to the axis of the shield) of $21.062\mu\text{T/A}$ was applied in place of the transverse field. This test explored the effect on shielding performance in the Z axis due to an open end.

The following Table lists the measured shield performance for Test Conditions 2 and 3 at different frequencies:

Test	Ratio dB	Ratio dB	Ratio dB
Condition	1Hz 1Hz	55Hz 55Hz	210Hz 210Hz
#2	439,788:1 (112.86)	103,075:1 (100.26)	55,317:1 (94.87)
#3	205:1 (46.24)	2,016:1 (66.09)	2,631:1 (68.40)

The following chart combines actual and extrapolated results for each test condition in an effort to predict shielding performance in frequencies up to 210Hz.

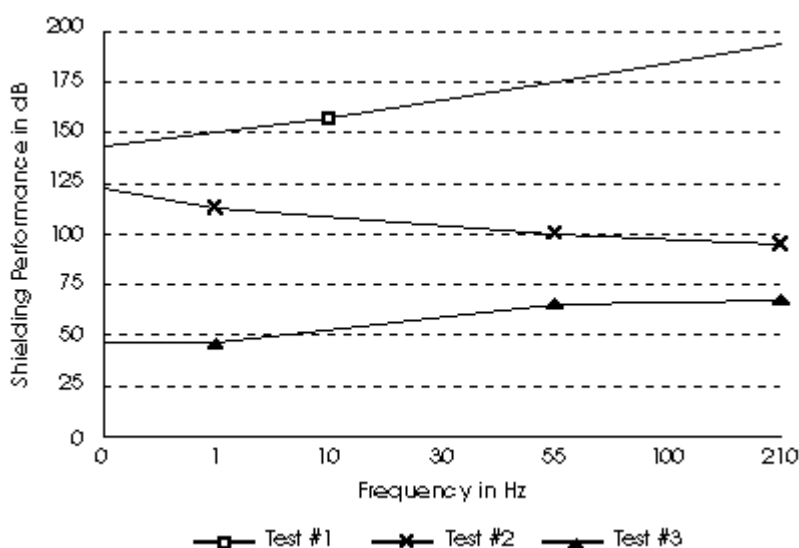

Conclusions

1. This four-shell nested cylinder provided the low magnetic noise environment needed for testing extremely sensitive instruments such as SQUIDs and to perform NDE.
2. High performance magnetic shielding with multilayer nested cylinders requires closure of open ends. Otherwise, shielding performance values will be reduced due to "end effects".
3. In the case of an assembly with one end open, the penetration of magnetic flux into the interior of the multishell nested cylinder is different from the theory developed for the magnetic behavior of one-shell configurations. The most striking deviations are:
 - a. Field perpendicular to the axis: in the depth of the cylinder, there is only a slight reduction of the shielding ratio with rising frequency. This is believed to be the result of increasing shielding performance due to eddy currents.

b. Field parallel to the axis: in the depth of the cylinder, there is a significant increase of shielding performance with rising frequency, due to the impact of eddy currents.

Amuneal Manufacturing Corp. wishes to acknowledge the contributions to this Product Bulletin by Dr. H. Soltner of KFA/ISI and Dr. K.-J. Best of Best Engineering, Hanau, Germany. For further information, please contact Mr. Adam Kamens at 215-535-3000, by fax at 215-743-1715, or by email at adamk@amuneal.com.

[Close Window](#)